

BOYER BRANDSEN ELECTRONICS LTD

Frindsbury House, Cox Lane, Detling, Maidstone, Kent ME14 3HE. ENGLAND
Telephone: 0044 (0)1622 730939 Fax: 0044 (0)1622 730930 www.BoyerBrandsen.com

KIT 00381

MICRO-POWER IGNITION SYSTEM FOR TRIUMPH/BSA. 12V TWIN CYLINDER TWINPLUG MOTOR CYCLES

THIS SYSTEM WILL ONLY WORK WITH THE SPECIAL DUAL OUTPUT DIGITAL IGNITION COILS TYPE 00008. 5000 OHM SUPPRESSED SPARK PLUG CAPS MUST BE FITTED

Comprising:-

- a) Transistor Box Part Number BOX00212 (BLUE box with wires)
- b) Stator Plate (round printed circuit board with two coils marked NT1a)
- c) Magnetic Rotor (round plated steel unit with two magnets)
- d) 1.25" x 0.25" BSF bolt
- e) 1.25" x 0.25" UNF bolt
- f) Long Plastic Tie Strap
- g) Coil Positive Earthing Wire, Red 1ft.
- h) 2 x Coil link wire, Black 1ft
- i) 4 x Coil bolts/nuts/washers, 4 x Coil HT Brass Clips, Rubber Boots & 8 x Small Plastic Tie Straps
- j) Terminals: 4 Female Spades, 1 Piggyback, 1 Male Spade, 2 Male Bullets & 1 Ring.
- k) 2 x Dual output digital ignition coil
- l) Four NGK suppressed plug caps
- m) 1.5m HT lead

General fitting instructions

Note:-

These instructions are a general guide to fitting the system to various machines with ignition coils, wiring, battery in different positions; thus it may be necessary to modify the length of some wires to complete the installation. If so, all connections should be of the highest quality, twisted wires will not give a satisfactory operation. Suppressed plug caps of 5000 ohms must be used with this system as radio frequency radiation can interfere with the microprocessor within the unit.

- 1) Remove the petrol tank and/or seat to gain access to the ignition coils, condensers and wiring.
- 2) For safety, remove one battery connection (or fuse).
- 3) Remove contact breaker plate and auto-advance unit.
- 4) The two wires going to the contact breakers are used to feed the triggering pulse to the transistor box and must be traced up to the ignition coils and condensers and removed from them. These are normally black-white and black-yellow wires.
- 5) Remove the wires going to the other terminals and remove the ignition coils and condensers. These will be the negative feed wires from the ignition switch.
- 6) Fit the new ignition coils in a convenient place hanging down from their mountings. Fit new ht cables and plug caps.
- 7) For positive earth installations; using the red positive earthing wire, and piggyback terminal; connect the positive of the first ignition coil to a good earthing point on the frame or the positive terminal of the battery.
- 8) Find a suitable position for the transistor box near to the ignition coils. Use the black plastic strap or tape for fitting.
- 9) Connect the black wire from the transistor box to the negative of the second coil.
- 9b) Fit a coil linking wire between coil 1 negative (-) and coil 2 positive (+).
- 10) Connect the red wire from the transistor box to the positive terminal of the coil - the same point to which the coil earthing wire feeds.
- 11) Connect the white wire from the transistor box to one of the negative feed wires from the ignition switch. These were taken off the ignition coils in step (5) above.
- 12) Connect the black-yellow wire from the transistor box to the black-yellow wire that goes down to the contact breaker housing.
- 13) Connect the black-white wire from the transistor box to the black-white wire that goes down to the contact breaker housing.
- 14) Tape the ends of any spare wires and check all connections are good and tight.
- 15) Remove timing inspection cover from alternator side of engine.
- 16) Set engine to the full advance timing mark on compression.
- 17) Fit the magnetic rotor onto the end of the camshaft in the contact breaker housing using one of the cap head screws, two different threads being provided. This should be finger tight; if the thread is too long a small amount should be cut off the end.
- 18) Hold the stator plate in the contact breaker housing and with it half way along its adjustment slots, turn the magnetic rotor on its taper until the magnets line up through the appropriate timing hole. If the back face of the magnet, in the direction of rotation, is made to line up with the back edge of the hole, very little adjustment will be required when strobe timing. This must be done without turning the engine. See Diagram.
- 19) Tighten the rotor cap head screw and re-check engine position and rotor alignment.
- 20) Fit stator plate with the standard pillar screws. Do not over tighten.
- 21) Connect the black-yellow and black-white contact breaker wires to the corresponding wires on the stator plate, using the male bullet connectors.
- 22) Refit tank, battery and seat.

23) Start engine and run for 4 to 5 minutes to warm up. Connect the strobe lamp and time with the engine running up to 4000 R.P.M. This is done by moving the stator plate on its slotted holes. If the timing is not obtainable before the end of the adjustment, the magnetic rotor will need to be slackened off and moved a small amount until the timing can be obtained.

24) Refit timing and contact breaker cover. The timing is now set and requires no further adjustment, but ignition coils, switch, battery, HT cables, plugs and plug caps must be in good order.

General Data

- 1) This unit can run positive or negative earth as long as the ignition coils are fed from the positive supply.
- 2) The working voltage is 10 to 16 volts.
- 3) With this system the ignition coil current is controlled by the microprocessor, when static the current is approx. 50mA, when running 1.0 amp with a 6.0 amp. pulse on switch on.
- 4) The resistance of the coils on the stator plate should be 66 ohms each, and the magnetic rotor should have the south poles of its magnets pointing outwards.
- 5) This unit can be adapted to work on many types of engine, if firing is required every 180° camshaft or 360° crankshaft driven.
- 6) This unit will drive two coils up to 15,000 sparks/minute.
- 7) Typical working advance range is 12° at 2,500 R.P.M. camshaft.
- 8) The unit and the peak primary voltage is regulated at 400 Volts.
- 9) This unit must always be operated with the frame or chassis acting as an electrical return, whether positive or negative earth. Also, if the engine is rubber mounted a good earth strap must be provided.
- 10) This unit will operate from an alternator, rectifier, zener diode and capacitor battery-less system, but kick-starting may be more difficult. (IF THE ZENER DISCONNECTS WHEN THE ENGINE IS RUNNING THE IGNITION WILL BE DAMAGED). For this reason we recommend our POWER BOX UNIT. This is voltage controlled and cannot damage the system.
- 11) Wiring should be trimmed to the correct length; spare wire should never be coiled up as this can affect the correct running of the ignition system. If possible the wires from the stator plate should be run separately from the main wiring loom.
- 12) With this system both spark plugs are fired at the same time, thus if the engine only runs on one cylinder the fault can only lie with the mechanics of that cylinder, spark plug, lead or ignition coil, not the transistor box or stator plate. To run with a twin plug system two coils can be run in series, with each firing both cylinders. (NOT ONE COIL TO EACH CYLINDER).

WARNING: THIS UNIT PRODUCES VERY HIGH VOLTAGES ALWAYS TURN OFF BEFORE WORKING ON THE SYSTEM.

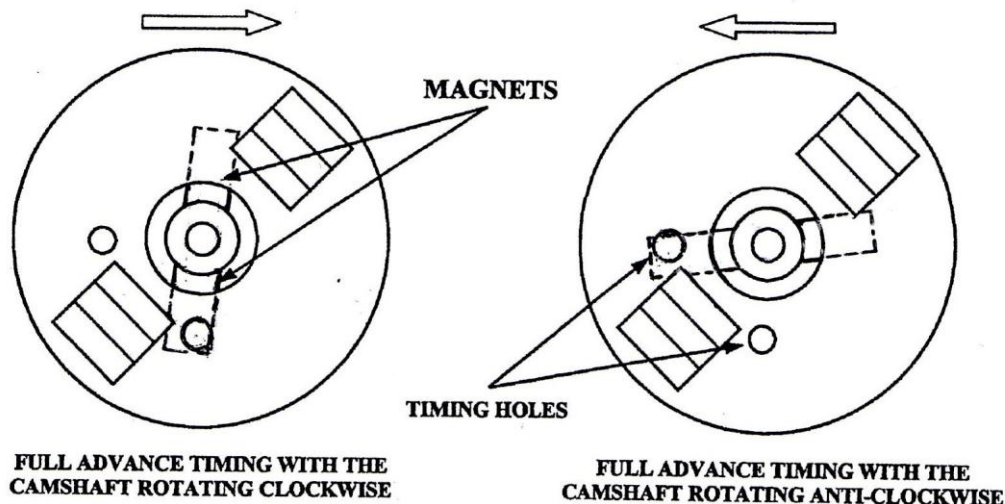

**BOYER BRANSDEN
ELECTRONICS LTD.**

03/02/03

5000 OHM RESISTANCE PLUG CAPS MUST BE USED

Fig. 1

BOYER BRANSDEN
MICRO-POWER DIGITAL
DUAL OUTPUT COILS (COIL00008)

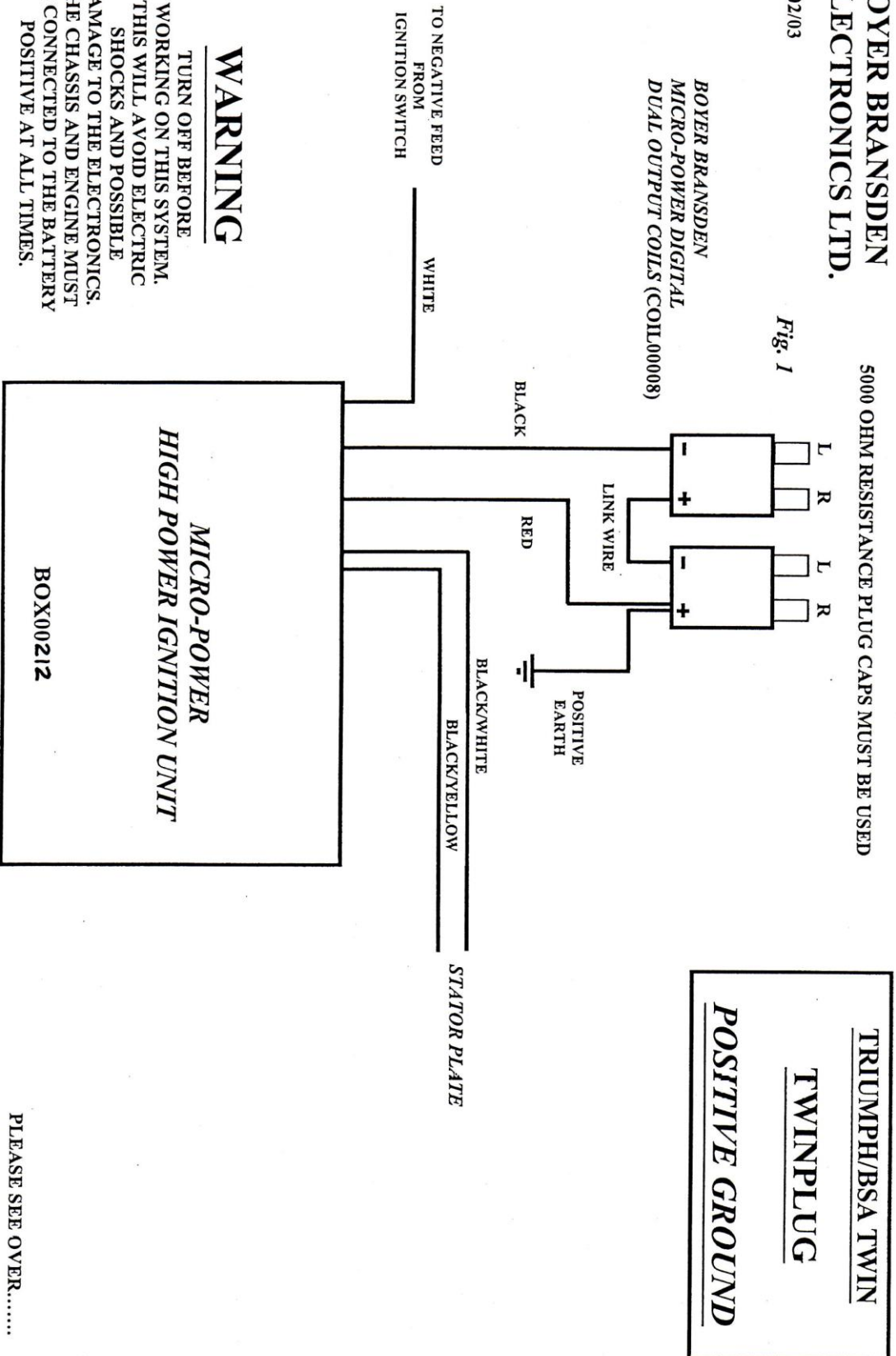

**TRUMPH/BSA TWIN
TWINPLUG
POSITIVE GROUND**

WARNING

TURN OFF BEFORE
WORKING ON THIS SYSTEM.
THIS WILL AVOID ELECTRIC
SHOCKS AND POSSIBLE
DAMAGE TO THE ELECTRONICS.
THE CHASSIS AND ENGINE MUST
BE CONNECTED TO THE BATTERY
POSITIVE AT ALL TIMES.

PLEASE SEE OVER.....

**BOYER BRANDSDEN
ELECTRONICS LTD.**

03/02/03

5000 OHM RESISTANCE PLUG CAPS MUST BE USED

Fig. 1

**BOYER BRANDSDEN
MICRO-POWER DIGITAL
DUAL OUTPUT COILS (COIL00008)**

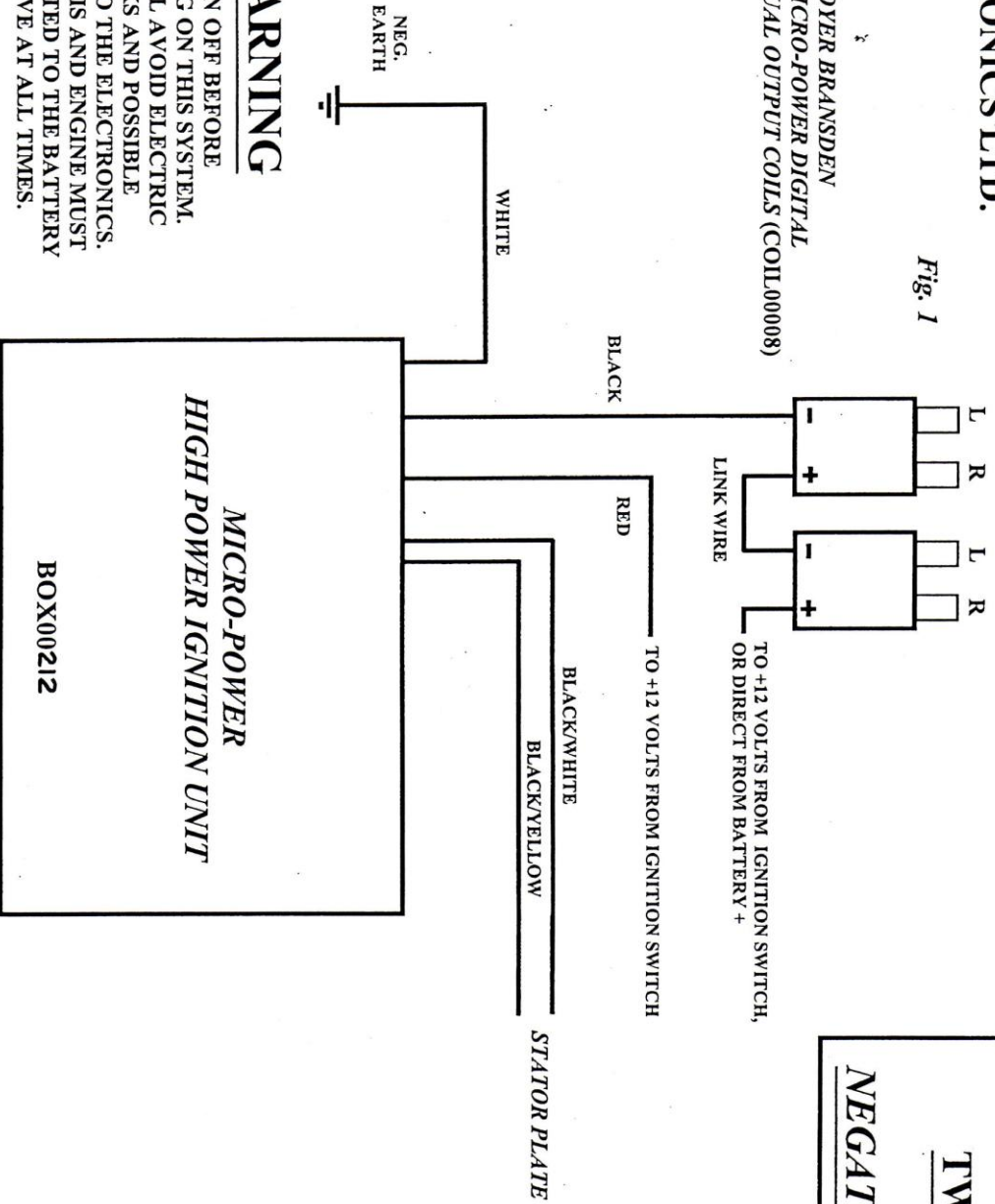

**TRUMPH/BSA TWIN
TWINPLUG
NEGATIVE GROUND**

WARNING

TURN OFF BEFORE
WORKING ON THIS SYSTEM.
THIS WILL AVOID ELECTRIC
SHOCKS AND POSSIBLE
DAMAGE TO THE ELECTRONICS.
THE CHASSIS AND ENGINE MUST
BE CONNECTED TO THE BATTERY
NEGATIVE AT ALL TIMES.

PLEASE SEE OVER.....