

BOYER BRANSDEN ELECTRONICS LTD

Frindsbury House, Cox Lane, Detling, MAIDSTONE, Kent ME14 3HE ENGLAND
Telephone: 01622 730939 Fax: 01622 730930



KIT 00288

MICRO-POWER IGNITION FOR KAWASAKI Z400J-Z1000, Z1 & SOME ELECTRONIC MODELS. THIS SYSTEM WILL ONLY WORK WITH THE SPECIAL DIGITAL IGNITION COILS TYPE BB 00008. WITH THIS SYSTEM 5000 OHM SUPPRESSED PLUG CAPS MUST BE FITTED.

Comprising:-

- a) Transistor Box (Red box with wires)
- b) Stator Plate (round printed circuit board with two coils) Z400J - Z650: small stator plate (type KH1a) ; Z1, Z900, Z1000:(type Z900/1000) large stator plate
- c) Magnetic Rotor (round plated steel unit with two magnets)
- d) Plastic strap
- e) Blue 3M connector
- f) Black & Green wires in black sleeving, 90mm long-stator plate to ignition box connection (electronic models) Terminals 2 male bullets, 2 small rings.

Fitting instructions:

(Tools required are the standard tool kit plus 13mm socket spanner and strobe lamp.)

- 1) Open seat, fully disengaging seat stay and remove tool kit.
- 2) Turn off petrol tap and remove pipes.
- 3) Undo the rubber strap holding the rear of the petrol tank. Lift, draw back and remove.
- 4) Fit the transistor box into place using the plastic strap. See Fig.1
- 5) Remove the ignition coils and disconnect the green, black, and red/yellow wires from points and wiring harness.
- 6) Reconnect the green and black wires as in Fig.1
- 7) Run the long black wire back along the frame to the NEGATIVE (-) terminal of the battery.
- 8) Connect the red/yellow wire from the transistor box to the red/yellow wire from wiring loom. Fit the new coils in place of the old ones, refit HT cables. Fit coil link wire and connect green and red/yellow wires. (See Circuit Diagram)
- 9) Check ALL connections are good and tight. Replace petrol tank and pipes. (The connectors on the black and green wires may be protected by covering with PVC tape)
- 10) Remove the contact breaker cover on the right hand side of the engine and undo the three screws holding the contact breaker plate/trigger and remove. Disconnect the black and green wires using pliers on the 3mm nuts.
- 11) Remove the centre bolt from the auto-advance unit using the 13mm socket spanner. NB: The engine positioning nut is replaced by the magnetic rotor and is not used.
- 12) Turn the auto-advance cam/reluctor clockwise, moving the bob weights out, and pull off the advancer shaft.
- 13) Connect the green and black wires to the two marked terminal screws on the stator plate unit.
- 14) Fit the stator plate into the contact breaker housing with the hole for timing at the top, using the three screws, setting it half way along the adjusting slots.
- 15) Place the magnetic rotor on the centre bolt with the two magnets away from the head, replace the bolt and hand tighten.
- 16) The magnetic rotor supplied has no direct location on the advancer shaft and can be fitted in any position. This is due to the dogs on the advancer shaft being placed in various positions by the manufacturer. The method of setting is shown in Fig.3. Set the engine to the (T) Top Dead Centre position mark on 1.4 or 2.3 cylinders. Move the rotor to the position shown in Fig.3, with the magnets in line with the centre of the pole pieces on the stator plate. Tighten the centre bolt. A small tap on the end of the rotor will give small indentations inside the rotor, these can be filed out to provide greater location and give a refitting position if the rotor is removed. (This can be done after strobe timing, recheck after final fitting).
- 17) Start the engine and run for five minutes to warm up engine and ignition unit.
- 18) Connect the strobe lamp and time to the Full Advance marks with engine at 5000 RPM. Align by moving the stator on its slotted holes. The electronic advance can be seen by accelerating up from idle, A small amount of advance will be seen over 5000RPM - this is normal.
- 19) Check all screws are tight and refit the cover. (If the cover touches the rotor file out the dog marks as in instruction (16). The timing is now set and requires no maintenance, but carburation, plug caps and spark plugs must be in good order.

Z1, Z900 & Z1000 and machines with no Full Advance Timing mark:

A Full Advance mark should be made at 40° BTDC on the bikes original auto advance plate to aid strobe timing. Set the engine to T.D.C. by aligning the "T" mark on the auto advance plate with the engines reference pointer. From the 40° line on the stator plate, scribe a temporary mark to the magnetic rotor. Rotate the engine 320° clockwise (to keep the rotor bolt tight) until the scribed 40° mark aligns with the "T" mark at the 9 o/c position on the stator plate. Apply a "Fully Advanced" paint mark on the advance plate opposite the engines static reference pointer.

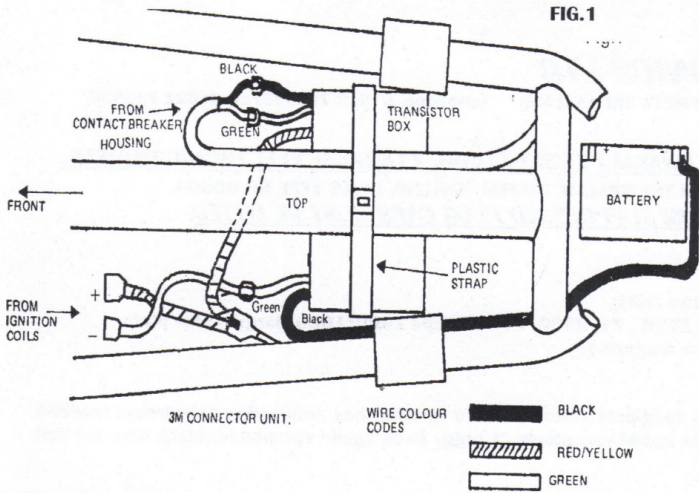
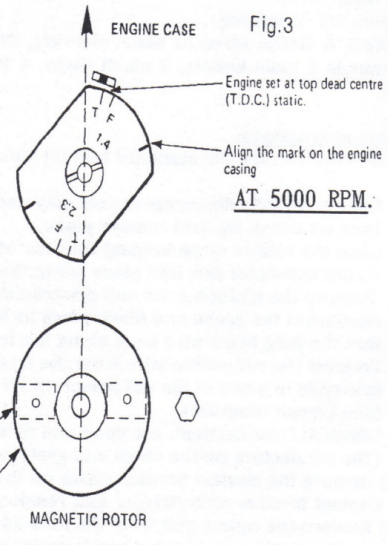
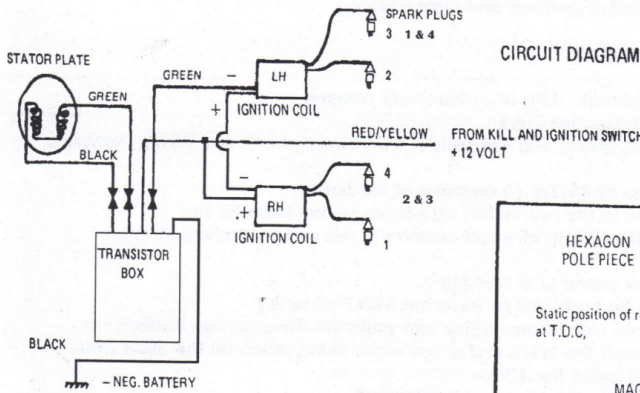
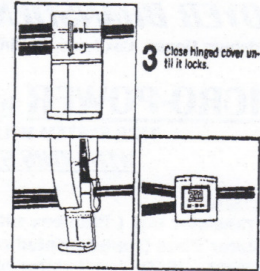

FIG.2

INSTRUCTIONS FOR SINGLE TAP CONNECTIONS:

- 1 Slip run wire into side channel. Insert un-stripped tap wire up to stop.
- 2 Make connection with pliers by driving "U" contact down flush with top of connector.



THIS WIRING SYSTEM CAN BE USED WITH THE MICRO-POWER IGNITION. NO CURRENT IS DRAWN WHEN THE IGNITION SWITCH IS OFF. ONLY 80mA IS DRAWN WHEN THE IGNITION IS ON WITH THE ENGINE STATIONARY. THE IGNITION SWITCH WIRING WILL ONLY CARRY THE 80mA. THIS REDUCES THE LOAD ON THE WIRING AND CAN IMPROVE COLD STARTING.

