

**MICRO-DIGITAL IGNITION SYSTEM FOR B.M.W. 1979-80 MOTORCYCLES****WITH THE CONTACT BREAKERS MOUNTED IN A SEMI-SEALED HOUSING**

ALSO TO REPLACE THE BOSCH SYSTEM ON LATER MODELS WITH SOME MECHANICAL MODIFICATION TO THE HOUSING AND WITH AN IGNITION COIL OR COILS OF 3 OHMS TOTAL PRIMARY RESISTANCE.

**Comprising:**

- a) Micro-Digital Electronic Box, Red. (BOX00040)
- b) Stator Plate , round printed circuit with two coils and two connecting wires. (STA00164)
- c) Magnetic Rotor , round plated steel unit with two magnets fitted. (ROT00113)
- d) Plastic straps (2 large, 2 small)

**Tools required:**

Standard machine toolkit, Small and medium screwdrivers, Small and large pliers, Allen keys for engine case and contact breaker unit  
Strobe light for final timing, Black P.V.C. insulating tape.

**Fitting instructions:**

- 1) Disconnect the battery or disconnect the thick wire from the negative terminal of the battery from its connection to the rear engine case just below the clutch cable. This is to reduce the chance of shorting the alternator diodes when removing the engine front cover.
- 2) Remove engine front cover (two Allen headed bolts).
- 3) Disconnect the single wire from the side of the contact breaker unit which is located at the bottom front of the engine by pulling off the spade connector. This is not used and can be taped up.
- 4) Remove the complete contact breaker unit by removing the two Allen headed screws on the left and right (These go through slotted adjustment holes). Pull out plastic vent pipe.
- 5) Take the contact breaker unit to a clean bench or table with good lighting and a small box to hold all the parts to be removed.
- 6) Dismantle the contact breaker unit as follows:-
  - (a) Remove inspection plate from the side by prising out with small screwdriver.
  - (b) Remove two 4mm screws from the top cover and remove cover.
  - (c) Remove two 4mm screws under the cover and remove bearing plate unit.
  - (d) Using a large pair of pliers, hold the lug on the large circlip. Pull, twist and remove.
  - (e) Remove the three 4mm screws from the side of the unit. Remove condenser by pulling off connector.
  - (f) Remove large rubber grommet from the side of the unit.
  - (g) Turn the contact breaker and mounting plate anti-clockwise approximately 1.5cm until the screw mounting lug is halfway across the big grommet hole, it should pull out of the housing.
  - (h) Using a small screwdriver prise off the circlip holding the contact breaker cam to the centre shaft.
  - (i) Remove the bob weight springs with small pliers and slide off the contact breaker cam.
  - (j) Using a small screwdriver and/or pliers, remove the two small circlips holding the advancer bob weights and remove.The stripping of the contact breaker unit is now complete.
- 7) Slide the magnetic rotor onto the centre shaft with the magnets and large flange against the bob weight mounting plate. The two bob weight pins must engage in the rotor, and this may mean bending out the outer spring mounting brackets. Any shim washers should be left in place.
- 8) Replace the circlip onto the centre shaft to hold rotor in place.
- 9) Remove the two screws and washers from the stator plate and fit into the housing with the coils and mounting brackets towards the top, the output wires feed through the square hole. Push over the three indents in the case until it sits flat. Fit and tighten the two small mounting screws. See Figure 1.
- 10) Replace the large circlip in the top of the housing along with the large rubber vent grommet. This may require a small flat cut on one side to clear the stator plate.
- 11) Replace top bearing plate and tighten the two screws.
- 12) Replace top cover and tighten the two screws, press side inspection plate back in.
- 13) Replace the whole unit back into the engine with it set halfway along its adjustment slots. Note that the drive coupling will only go one way around. Lightly tighten the two screws.
- 14) Route the cable up towards the top left hand side of the casing, and replace the vent pipe.
- 15) Remove petrol tank.
- 16) Fit the electronic box near to the ignition coils with the large plastic straps, depending on ignition coil layout, refer to Figure 2 or 2a.
- 17) Locate the original contact breaker wire coming from the top front of the engine casing just below the front ignition coil, remove this wire from the -1 coil terminal and tape it up (no longer used). Fit the new black wire from the electronic box to this coil terminal.
- 18) Connect the green wire from the electronic box to the +15 on the opposite ignition coil. This should have an original green wire already connected to it. Use the spare spade terminal on connector.
- 19) Run the brown earth wire back to a good earth point and secure.
- 20) Run the black/yellow-black/white wires down to the front engine case. Remove the rubber grommet and place the wires under it. Connect up to the wires from the points container.
- 21) Tidy and tie up the wiring, reconnect the battery and refill fuel tank.
- 22) Start engine and warm up (3-4 minutes running).
- 23) Remove timing rubber bung from engine casing and connect strobe light.
- 24) Time engine at 3500 r.p.m. on the full advance mark ( F dot) by adjusting the contact breaker housing on its slotted holes.  
**With twin plug, set timing 3 to 4 degrees retarded for best results.**
- 25) Remove battery earth wire and replace front engine cover. Replace earth wire and rubber timing bung. Installation is now complete.

**WARNING**

**HIGH VOLTAGES DEVELOPED FROM THIS SYSTEM CAN BE VERY DANGEROUS  
ALWAYS SWITCH OFF BEFORE WORKING ON THE SYSTEM.**

Fig. 1.

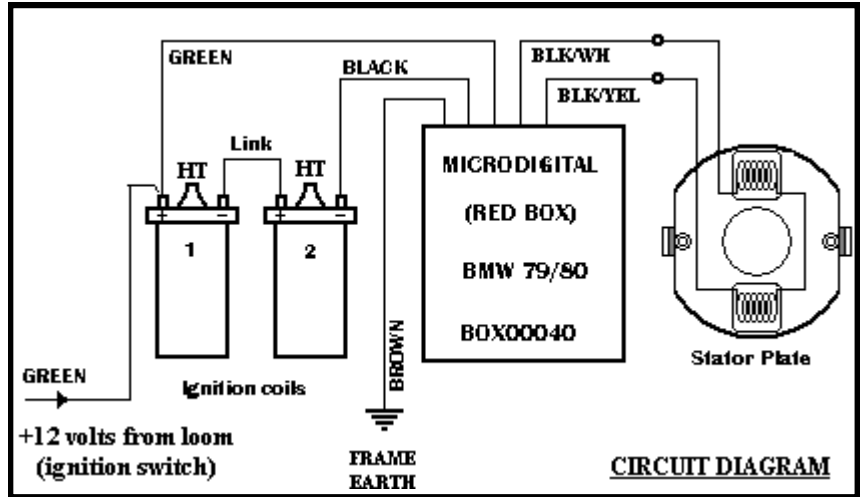

Fig. 2.

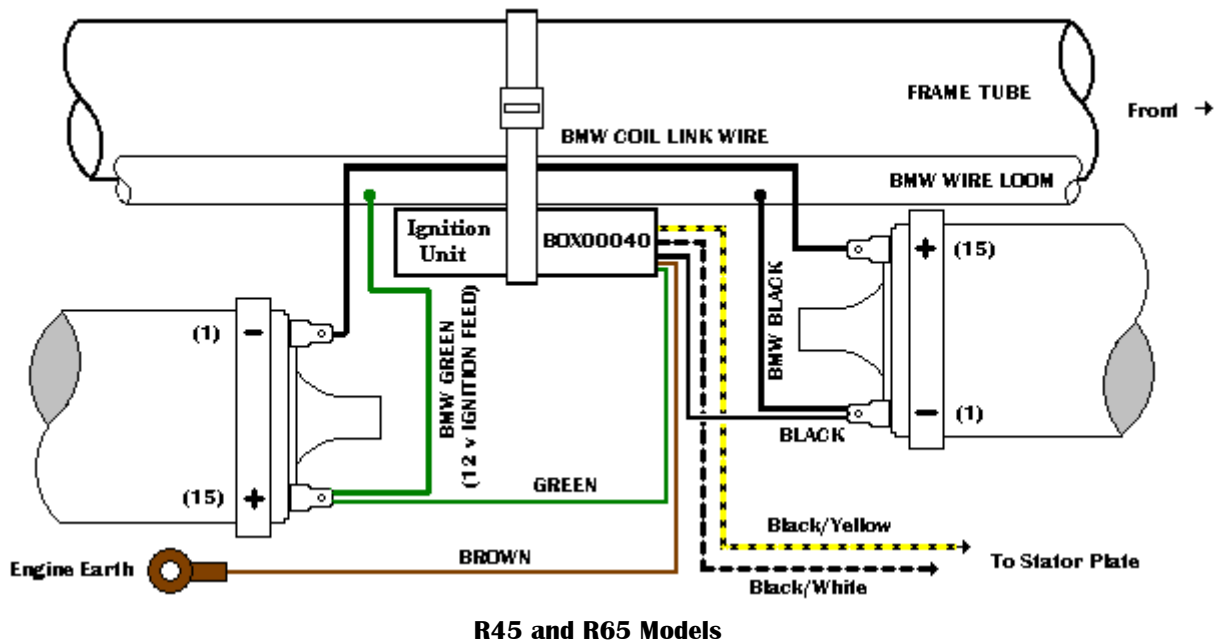

Fig. 2a.

